

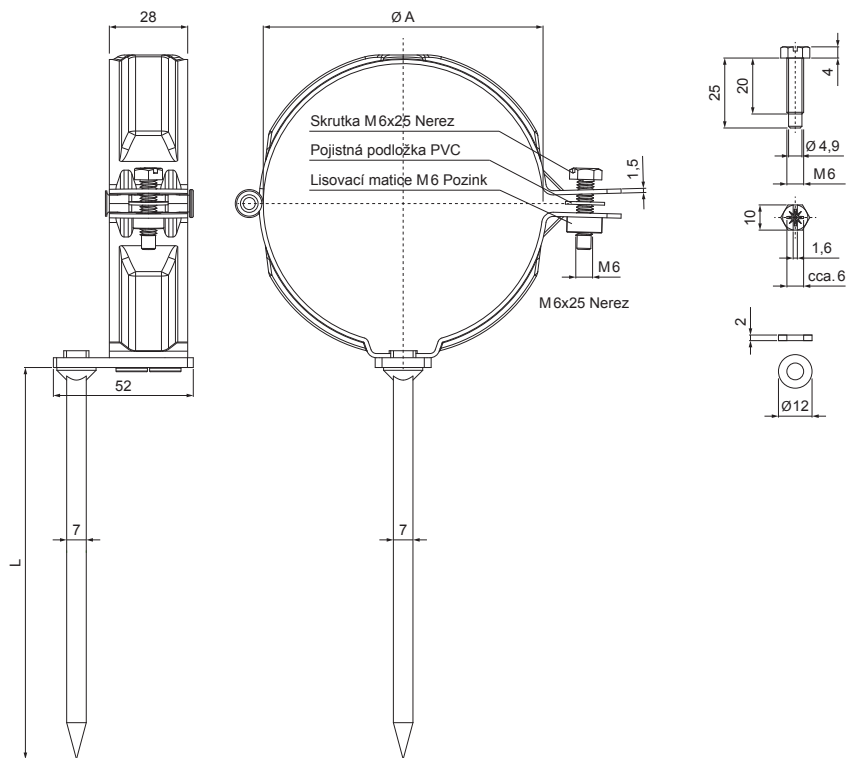



TECHNICKÝ LIST

# SVODOVÁ OBJÍMKA S TRNEM 300 MM

P-PODD



**TM** Pozink lakovaný – Testa di Moro – RAL 8028

INDEX	ZMĚNA	DATUM	PODPIS			
ZN. MAT.						
ROZM.–POLOT						
POM. ZAŘ.					STN	TR.Č.
VYPR.	Ing. Kluska M.				POZN.	Č.POZICE
PRESK.						
TECHNOL.	TECHNOL.				STARÝ V.	Č.V.
NÁZEV	Svodová objímka s trnem 300 mm				Počet listů	P-PODD
						List 

Vytvořeno: 22.04.2026 08:14:47

Technické změny vyhrazeny

Rozměry [mm]		
Jmenovitá velikost	Ø A	L
100	100	300