

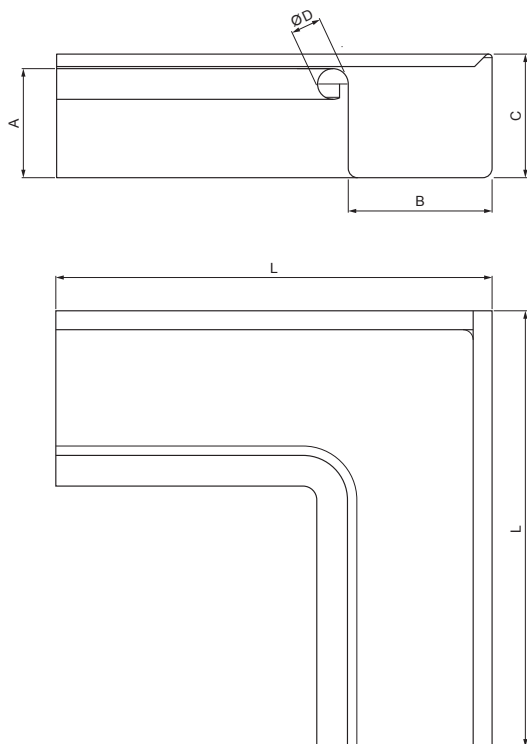



TECHNICKÝ LIST

# ROH VNITŘNÍ HRANATÝ

## W.15H-WRIH



**BHTM** Hliník lakovaný W.15 – Bílo hliníková tmavá W.15 – RAL 9007

INDEX	ZMĚNA	DATUM	PODPIS			
ZN. MAT.	T.O.		HMOTNOST kg			
ROZM.-POLOT			STN	TR.Č.		
POM. ZAR.	Ing. Kluska M.		POZN.	Č.POZÍCIE		
VYPR.	PRESK.		STARÝ V.	Č.V.		
TECHNOL.	TECHNOL.	NÁZOV		Roh vnitřní hranatý		
Počet listov			W.15H-WRIH		List 	

Rozměry [mm]					
Jmenovitá velikost	A	B	C	ØD	L
250	55	85	65	18	285
333	75	120	85	20	275

Vytvořeno: 07.06.2026 13:59:38

Technické zmeny vyhradené



TECHNICKÝ LIST

# ROH VNITŘNÍ HRANATÝ

# W.15H-WRIH



**BHTM** Hliník lakovaný W.15 – Bílo hliníková tmavá W.15 – RAL 9007

INDEX	ZMĚNA	DATUM	PODPIS		
ZN. MAT.	T.O.		HMOTNOST kg		
ROZM.-POLOT			STN	TR.Č.	
POM. ZAŘ.	VYPR. Ing. Kluska M.		POZN.	Č.POZICE	
PRESK.	TECHNOL.		STARÝ V.	Č.V.	
NÁZEV			Počet listů		
Roh vnitřní hranatý			W.15H-WRIH List 		

Vytvořeno: 07.06.2026 13:59:38

Technické změny vyhrazeny

Rozměry [mm]					
Jmenovitá velikost	A	B	C	ØD	L
400	90	150	100	22	400